

### step 1

open top box face down and raisetop onto packing pieces.  
ensure jiffy foam remains in place to protect polished surface of the top

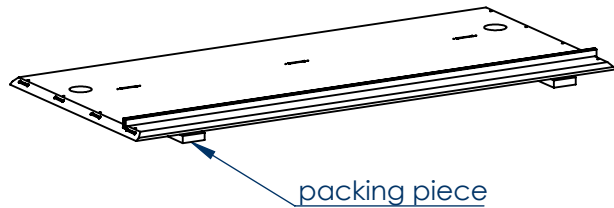

### step 2

identify correct end panel for each side of the top - these are marked with a letter or number. this is very important as joints have been test fitted prior to packing

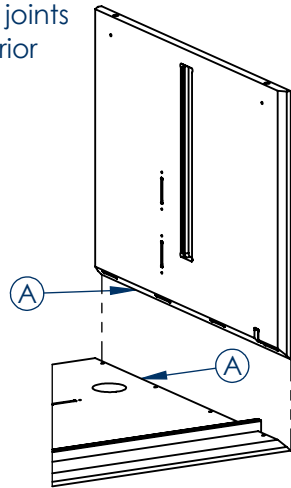

### step 3 - 2 people require minimum

locate first end panel on mitre fixings  
ensure ends are flush.

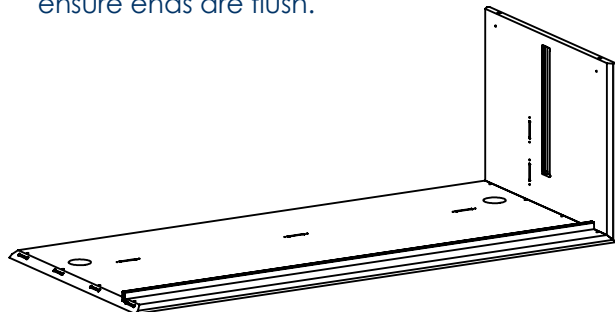

### step 4

tighten fitting with 4mm allen key  
**do not** overtighten as this will damage fixing

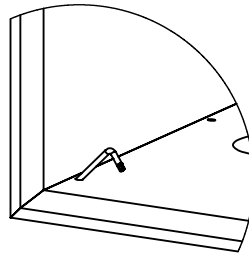

### step 5

locate modesty panel on to fixings  
ensure it is pushed up against the end panel  
**do not** tighten fixings until final leg is in place

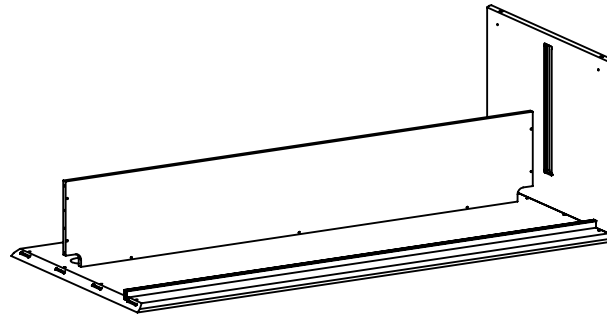

### step 6

locate second end panel on mitre fixings  
ensure ends are flush.  
tighten fitting with 4mm allen key  
**do not** overtighten as this will damage fixing

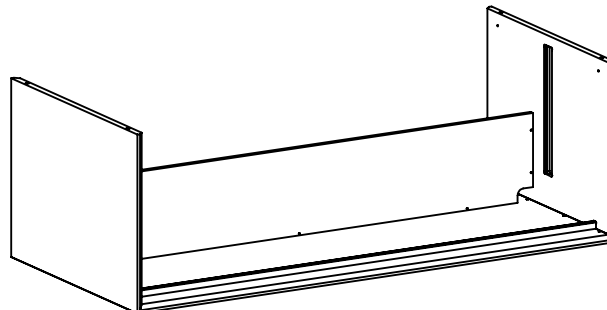

### step 7

secure modesty panel by tightening all remaining fixings

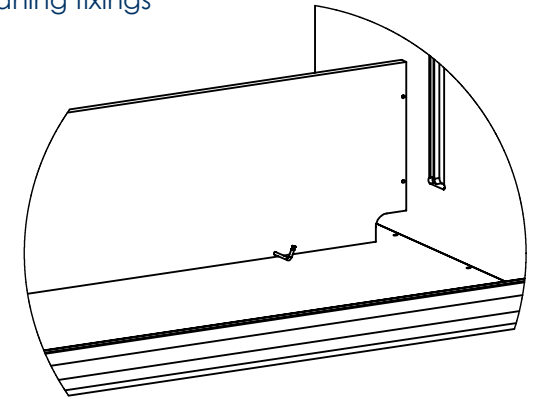

### step 8

carefully rotate desk into upright position  
all edges should be perfectly flush  
any slight edge can be gently manipulated into place using a rubber mallet on the inside face only  
finish off by rubbing a plain white of printer paper (not sandpaper) on tip of the mitre - this will leave a smooth edge

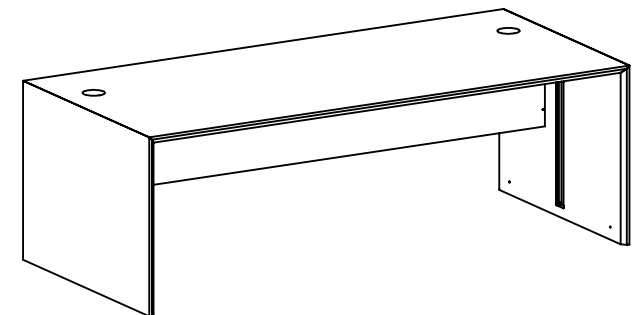

**Aston Free Standing Desk  
Assembly Instructions**

# VERCO

VERCO OFFICE FURNITURE LIMITED  
CHAPEL LANE, SANDS, HIGH WYCOMBE. HP12 4BG  
+44 (0) 01494 448000 [www.verco.co.uk](http://www.verco.co.uk)

AI\_0001 rev.0 PR 12/07/2017