

STEP 1.

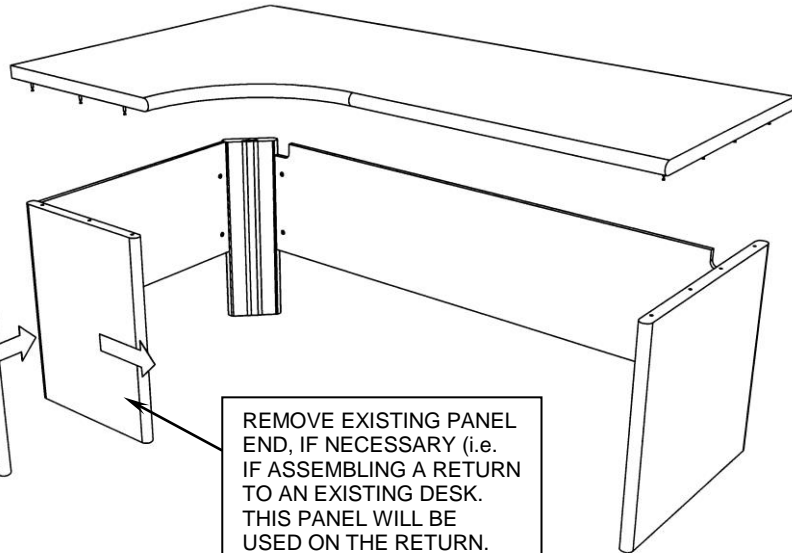

INSERT CUTBACK
PANEL END FROM
RETURN KIT.

REMOVE EXISTING PANEL
END, IF NECESSARY (i.e.
IF ASSEMBLING A RETURN
TO AN EXISTING DESK.
THIS PANEL WILL BE
USED ON THE RETURN.

STEP 2.

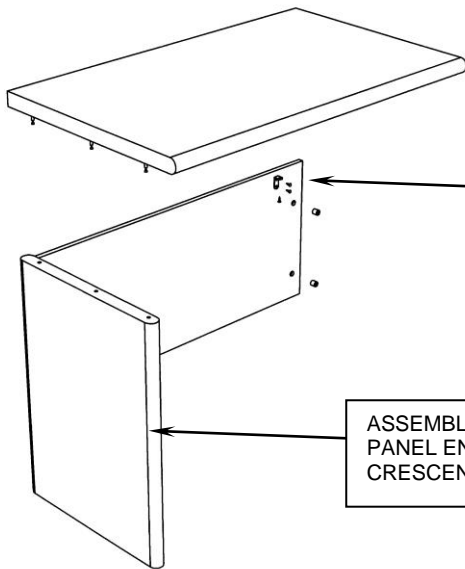

USE SMALL BRACKET TO
SECURE BACK PANEL TO
TOP. USE PILOT HOLE
PRE BORED IN TOP TO
LOCATE BRACKET.

ASSEMBLE RETURN USING
PANEL END TAKEN FROM
CRESCENT DESK.

STEP 3.

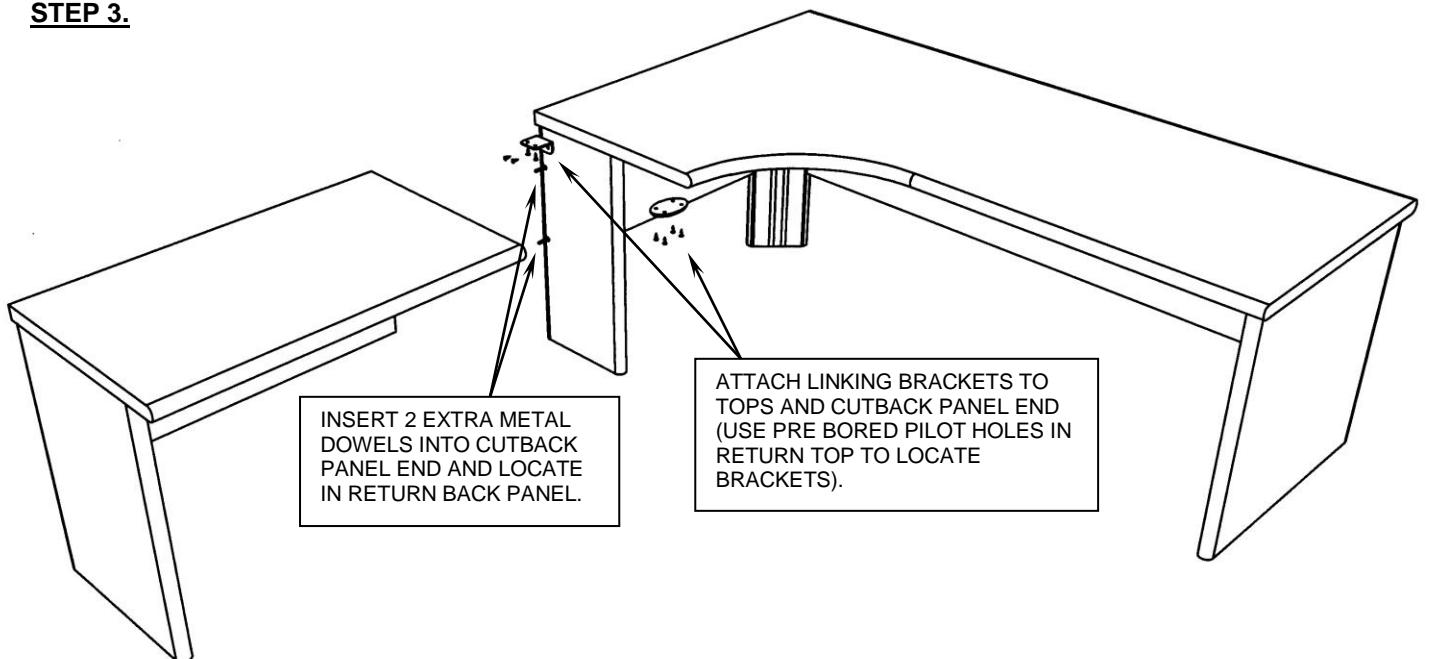

INSERT 2 EXTRA METAL
DOWELS INTO CUTBACK
PANEL END AND LOCATE
IN RETURN BACK PANEL.

ATTACH LINKING BRACKETS TO
TOPS AND CUTBACK PANEL END
(USE PRE BORED PILOT HOLES IN
RETURN TOP TO LOCATE
BRACKETS).