

Using the mallet secure the end of the beam fully into the leg by tapping at the end so as not to damage the top of the beam.

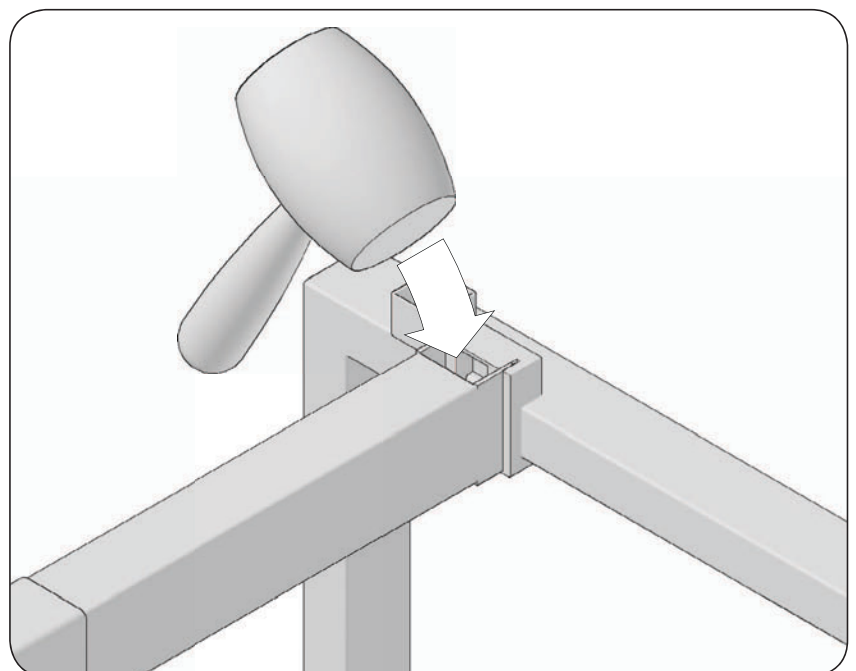

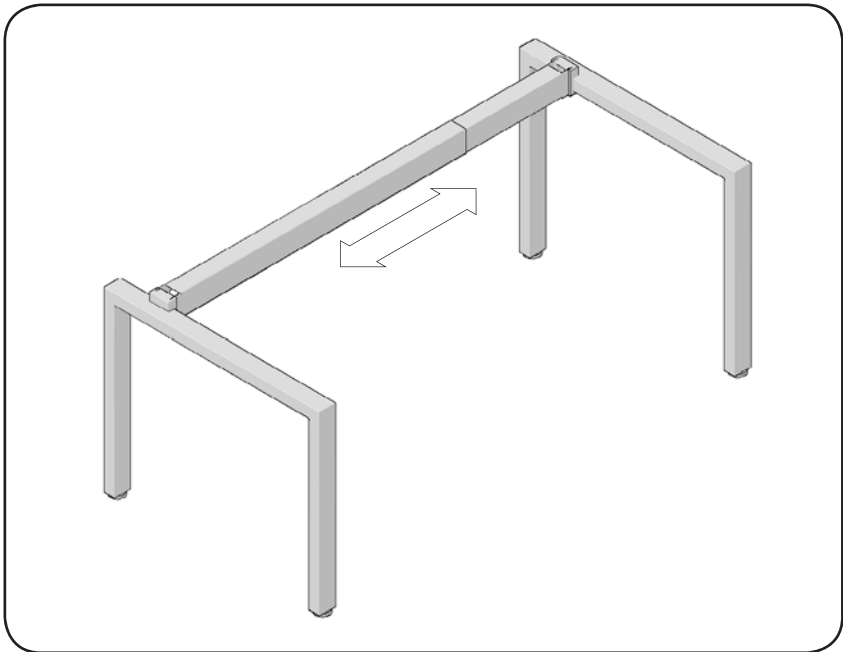

Ensure the bolt in the centre of the beam is loosened so it's length can be adjusted. Now adjust the width of the frame to roughly the width of the desk top using a tape measure or the top itself placed in front of the frame to check the width.

Take the four plastic spacers supplied with the legs (two with each leg) and place one over each of the holes in the leg frame, aligning the holes in each spacer roughly with the corresponding hole in the leg. The spacer has a small lip which should fit over the radius on the edge of the leg.

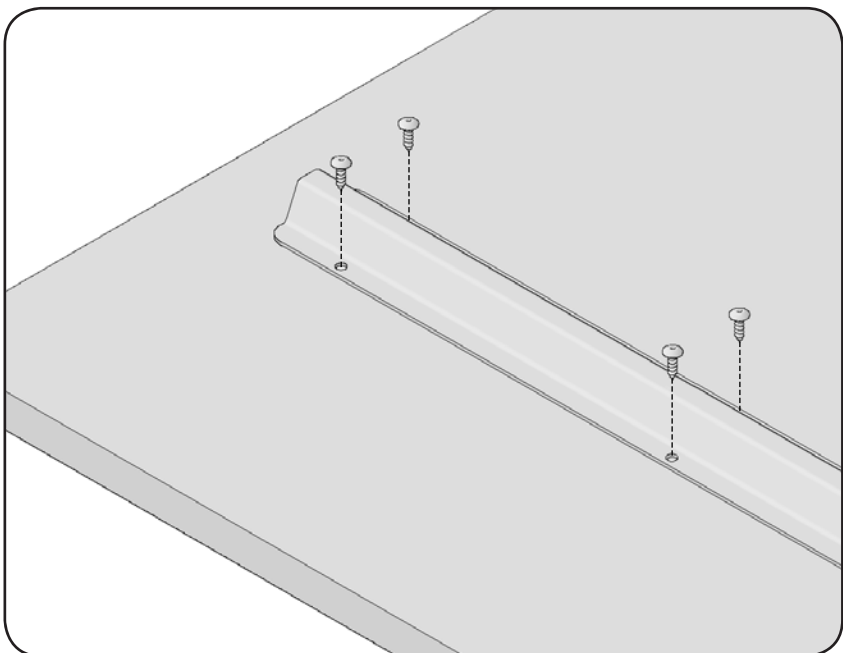
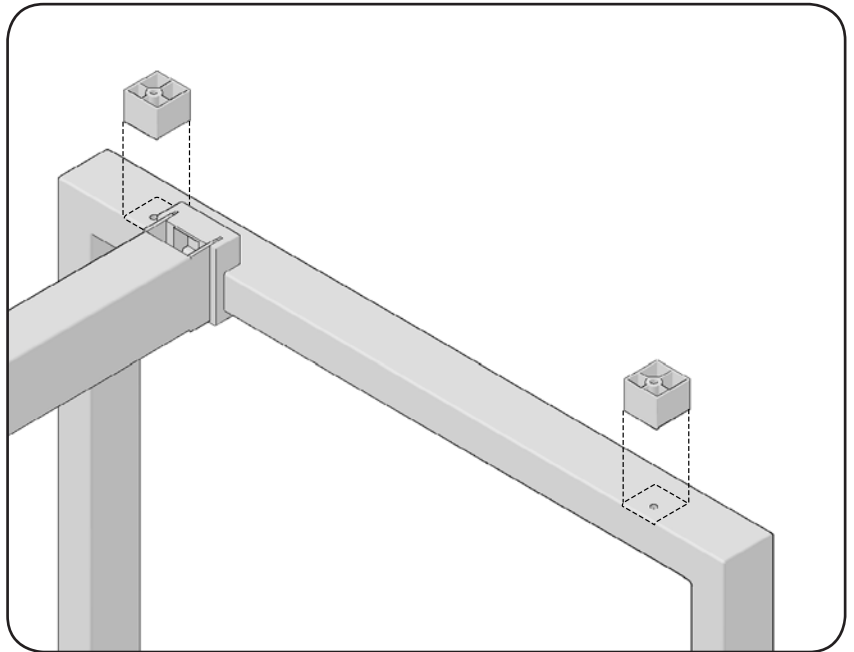

*Note: this step is only for desks with a support rail only i.e OVRD 1808/2008/2408.*

With the desk top turned upside-down, align the support rail with the corresponding pilot holes and screw into position using the 6mm x 26mm mushroom head screws provided.

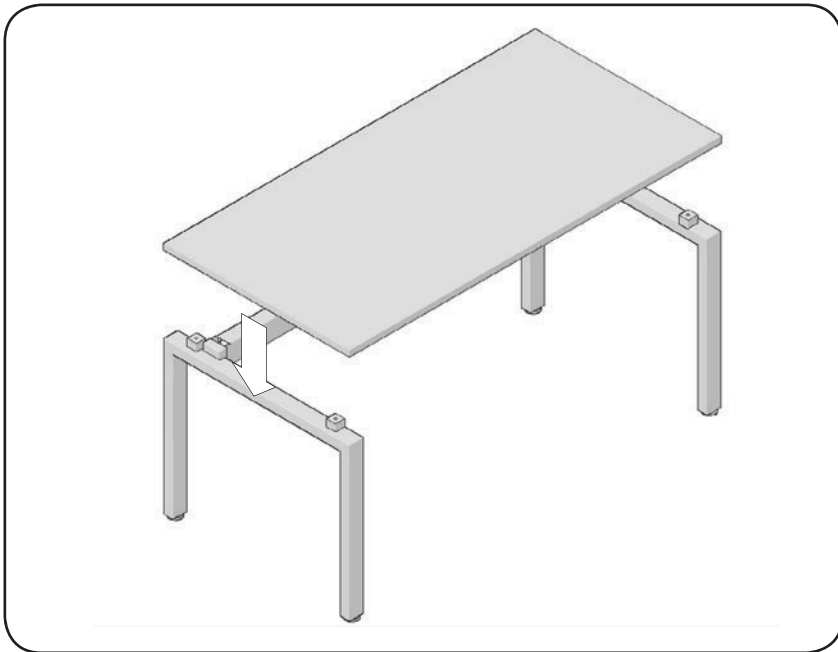

With the assistance of at least 1 other person, gently lower the top into position over the frame, resting it on the spacers and the beam. Once the top is in position, line up one of the legs more accurately with the end of the desk top taking care not to knock the spacers out of position.

Now insert one of the 5mm x 85mm bolts through the bottom of the leg frame and the spacer and into the bottom of the desk top. Screw in far enough that the bolt holds itself in position and repeat with the leg frame's other bolt. Once both bolts are in position fully tighten them.

Now repeat the same process for the other leg frame. You may need to shift the leg slightly in order to get the bolt through and into the desk top. Once both leg frames are secured, fix the beam by tightening the bolt in the bracket in the centre of the beam.

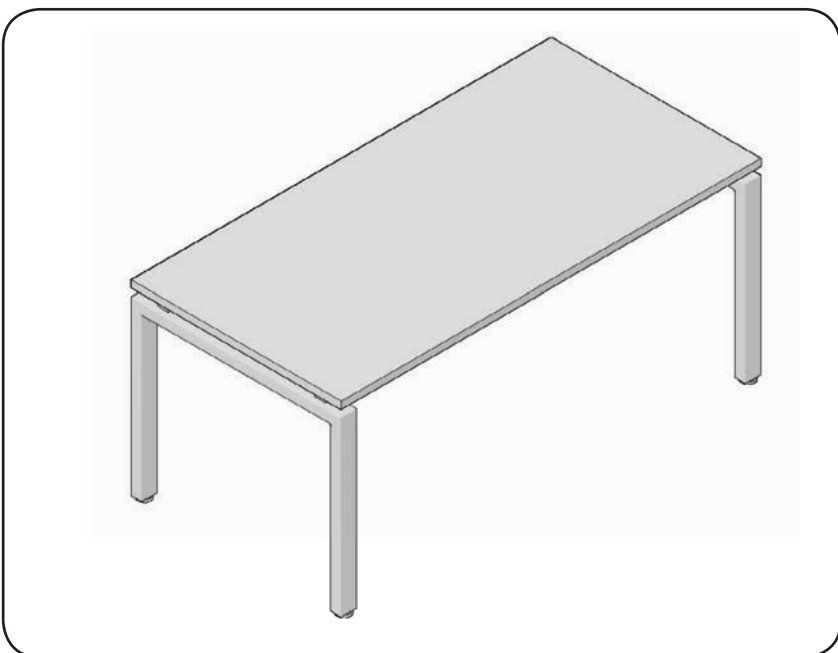
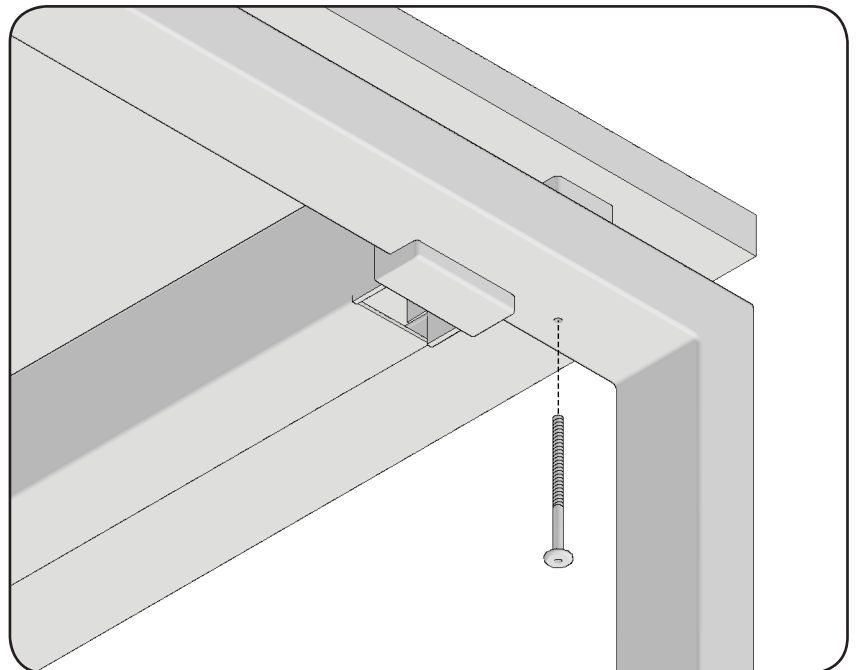

Congratulations, your desks is complete. Please refer to additional instructions for the fitting of screens, toolbars or any other accessories.